



Poor Reception or Interference on the Radio

SYMPTOM

1. Poor reception.
2. Electrical noise or engine noise from the speakers with the radio ON.

PROBABLE CAUSE

1. Corrosion of the antenna mast or tube or a damaged coaxial cable can cause poor reception.
2. Poor grounding of the antenna collar or tube or a damaged coaxial cable can cause electrical noise or static over the radio speakers.

DIAGNOSIS

The customer should be interviewed to get a thorough description of the symptoms and the conditions under which they occur (location, station, etc.).

NOTE:

- The information in this Service Bulletin applies to the Legend and NSX models. Where operations are similar, only the Legend model is illustrated. The NSX is illustrated when the operations are significantly different from those of the Legend.
- The connector number references are the same as those found in the appropriate Electrical Troubleshooting Manual (ETM).

Both the Legend and NSX have dual antenna systems. The radio uses both antennas (power mast antenna and rear window antenna) to choose the best signal for FM stations, but it uses only the power mast antenna for AM stations. So check the radio reception on AM stations first, even if that was not the customer's complaint.

- If you find poor reception on AM stations, then go to Diagnosis 1, Poor Reception.
- If you find electrical noise or interference on AM stations, then go to Diagnosis 2, Electrical Noise or Interference.
- If you find that the problem is only on FM stations, go to Diagnosis 3, Window Antenna Test.

Diagnosis 1. Poor Reception

1. Turn the ignition switch ON; then turn the radio on to extend the antenna mast.
2. Measure the resistance between the top section and the bottom section of the antenna mast.

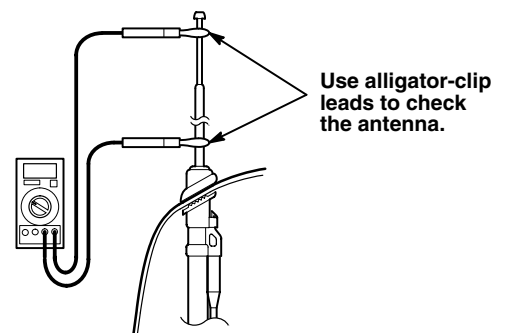

- If the resistance is more than 10 ohms, go to CORRECTIVE ACTION, Antenna Mast Replacement.
 - If the resistance is less than 10 ohms, continue with step 3.
3. Disconnect the coaxial cable from the antenna.
 4. Measure the resistance between the top section of the antenna and the center pin of the antenna male plug.

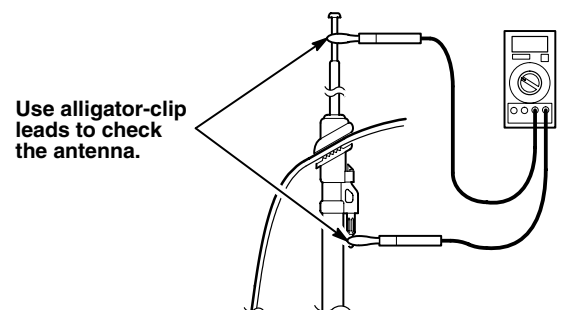

- If the resistance is less than 10 ohms, go to Power Antenna Coaxial Cable Test.
- If the resistance is more than 10 ohms, continue with step 5.

- Remove the antenna mast nut with the special tool; then remove the antenna mast.

ANTENNA NUT WRENCH
T/N 07JAA-001000C

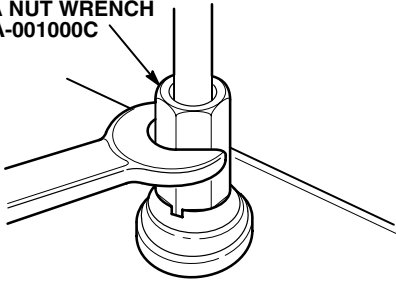

- Measure the resistance between the center pin of the antenna male plug and the threaded portion of the antenna tube.

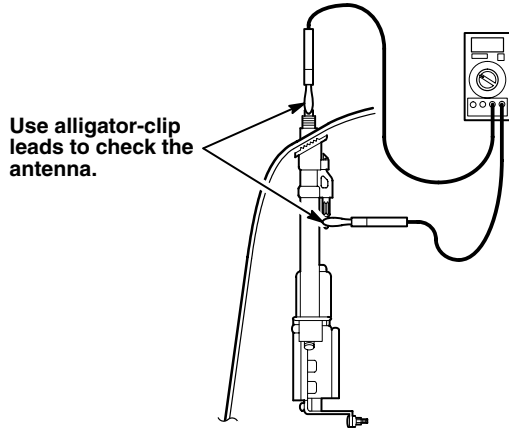

Use alligator-clip leads to check the antenna.

- If the resistance is less than 10 ohms, go to CORRECTIVE ACTION, Antenna Mast Replacement.
- If the resistance is more than 10 ohms, go to CORRECTIVE ACTION, Antenna Tube Replacement.

Diagnosis 2. Electrical Noise or Interference

- Disconnect the coaxial cable from the antenna.
- Measure the resistance between the antenna collar and body ground.

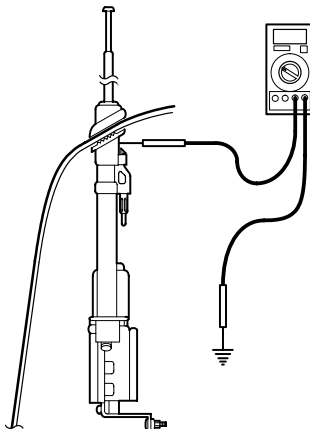

- If the resistance is more than 1 ohm, go to CORRECTIVE ACTION, Antenna Collar Replacement.
- If the resistance is less than 1 ohm, go to Power Antenna Coaxial Cable Test.

Diagnosis 3. Window Antenna Test

- Wrap aluminum foil around the end of one of the volt-ohmmeter test probes as shown. The aluminum foil keeps the test probe from damaging the antenna grids during the test.

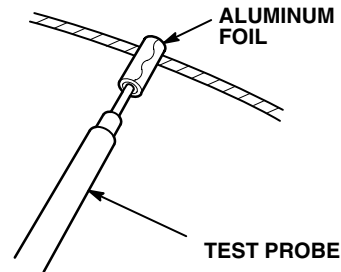

- Attach the other test probe with an alligator-clip lead onto the window antenna terminal (where the antenna lead contacts the window).

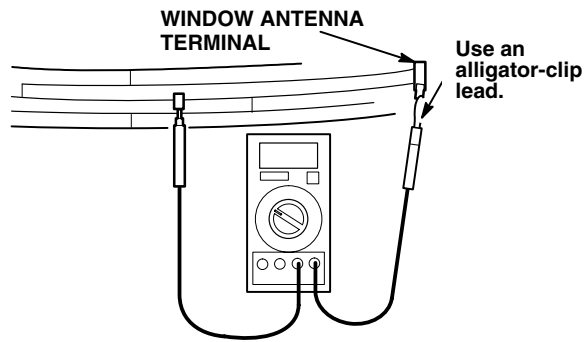

- Lift and move the test probe with the aluminum foil to touch the ends of each of the antenna grid lines on the window.
 - If the resistance is less than 1 ohm between each of the grid lines and the terminal, go to Window Antenna Coaxial Cable Test.
 - If the resistance is more than 1 ohm between any part of the grid lines and the terminal, go to CORRECTIVE ACTION, Window Antenna Repair.

Power Antenna Coaxial Cable Test

- Test drive the car to verify the customer's description of the symptom.
 - If the symptom cannot be reproduced, contact the customer for more information regarding the symptom.
 - If the symptom can be reproduced, continue with step 2.

- Disconnect the power antenna coaxial cable from the power antenna and from the radio.

- LEGEND**

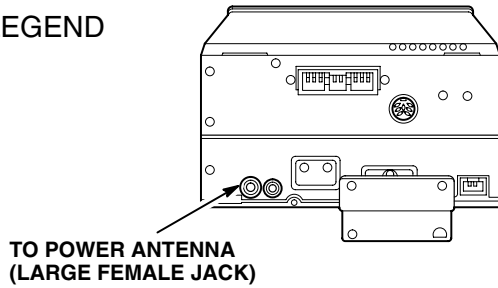

- NSX**

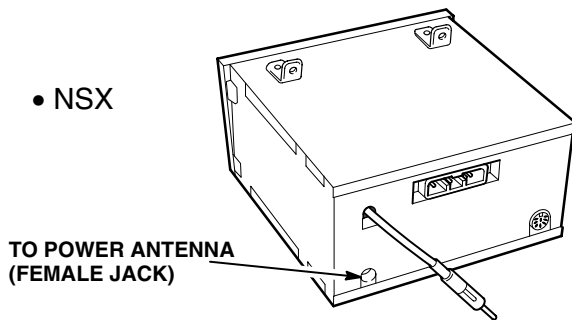

- Install a substitute coaxial cable (P/N 39159-SD4-A04) to the antenna; then run the substitute cable on the outside of the car, and connect it to the radio.

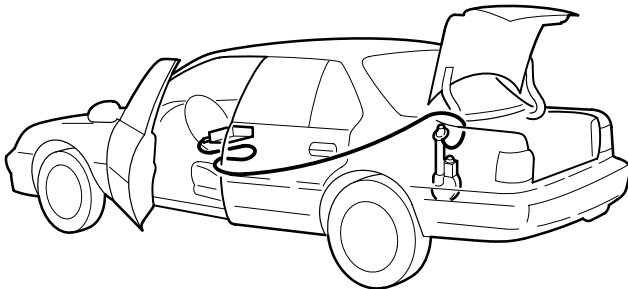

- Test the radio.
 - If the symptom has gone away, go to step 5.
 - If the symptom persists, continue troubleshooting the audio system.
- Disconnect the substitute coaxial cable from the radio; then reconnect the car's original power antenna front coaxial cable to the radio.

- Remove the following items to access the coaxial cable connector. SRS components are located in this area. Review the SRS component locations, precautions, and procedures in the SRS section of the appropriate service manual before continuing.

- LEGEND** – Remove the lower dash panel; then locate the power antenna coaxial cable on the left side of the steering column.

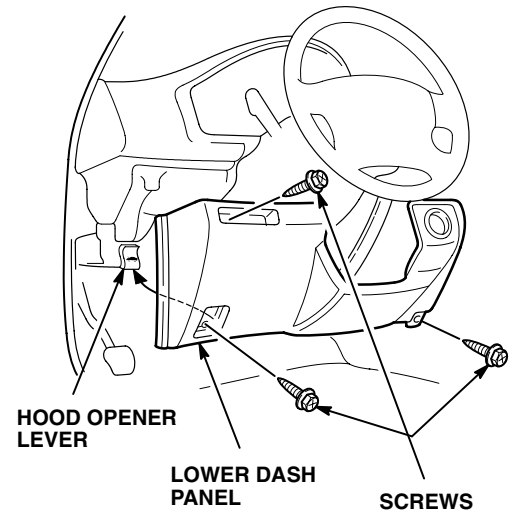

- NSX** – Move the driver's seat forward, and remove the rear upper trim panel; then remove the left rear trim panel. Locate the power antenna coaxial cable.

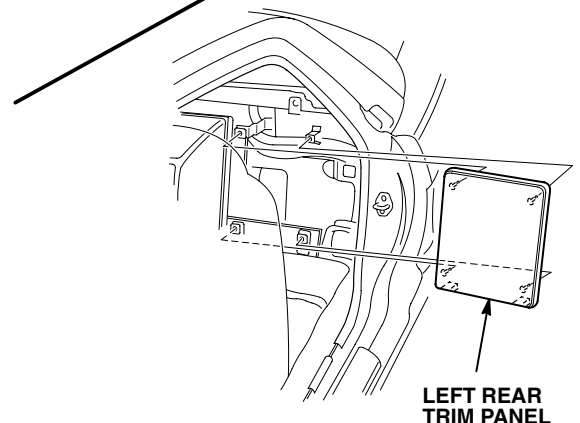
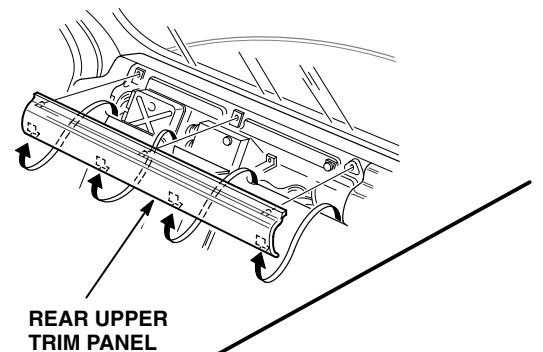

- Disconnect the power antenna coaxial cable connector; then connect the substitute coaxial cable to the power antenna front coaxial cable (radio side).

- LEGEND

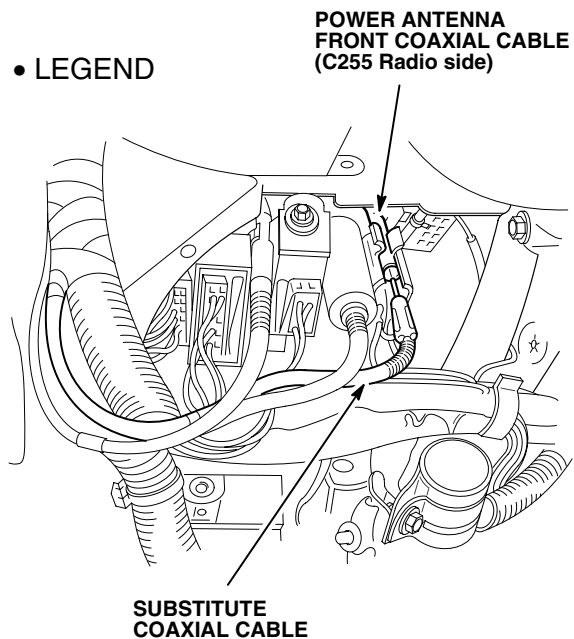

- NSX

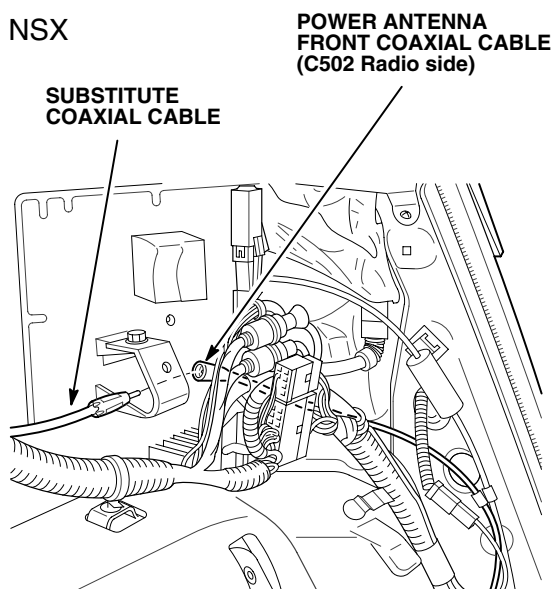

- Test the radio.
 - If the symptom has gone away, replace the rear power antenna coaxial cable. Refer to PARTS INFORMATION.
 - If the symptom persists, replace the front power antenna coaxial cable. Refer to PARTS INFORMATION.

Window Antenna Coaxial Cable Test

- Disconnect the window antenna connector at the rear window:

- LEGEND – Remove the right rear “C” pillar trim panel; then disconnect the window antenna connector.

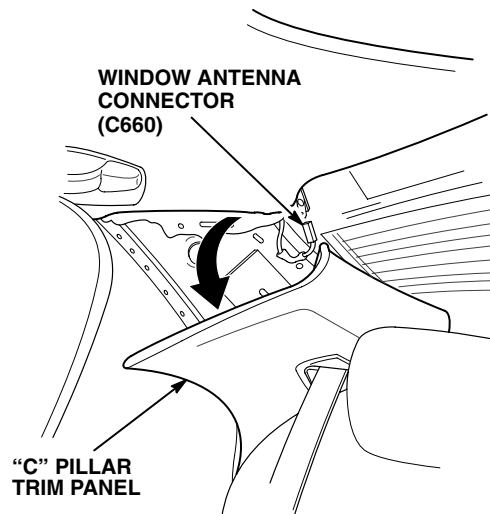

- NSX – Open the rear hatch, and remove the connector cover; then disconnect the window antenna connector.

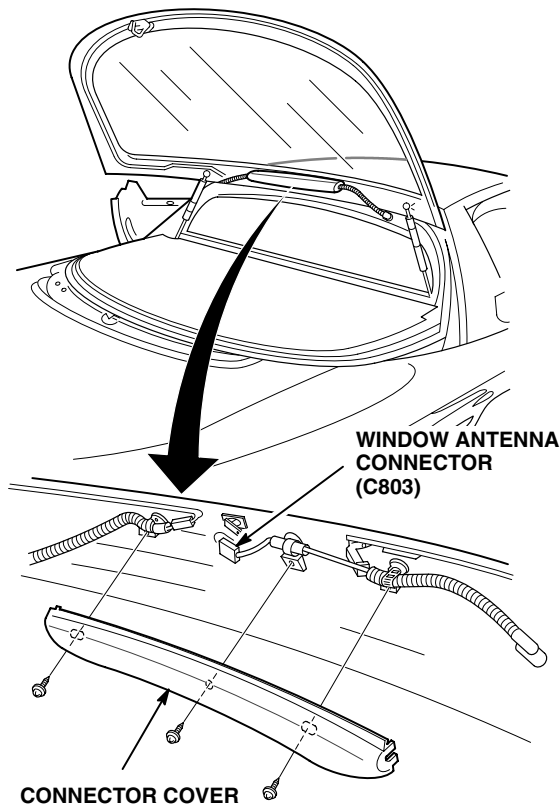

- Disconnect the window antenna coaxial cable from the radio.

- LEGEND**

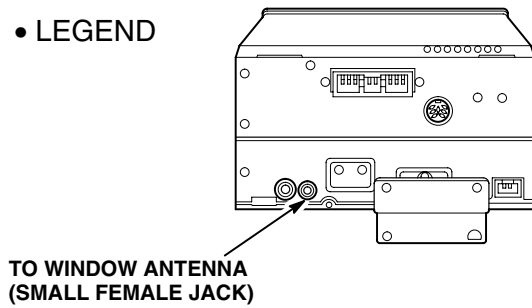

- NSX**

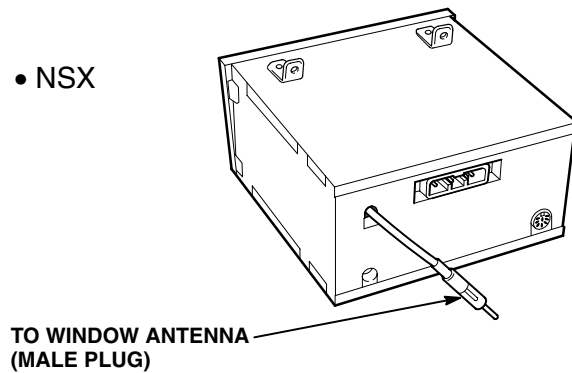

- Measure the resistance of the coaxial cable between the center of the window antenna plug/jack and the window antenna connector (Legend: C525 to C660, NSX: C503 to C803).

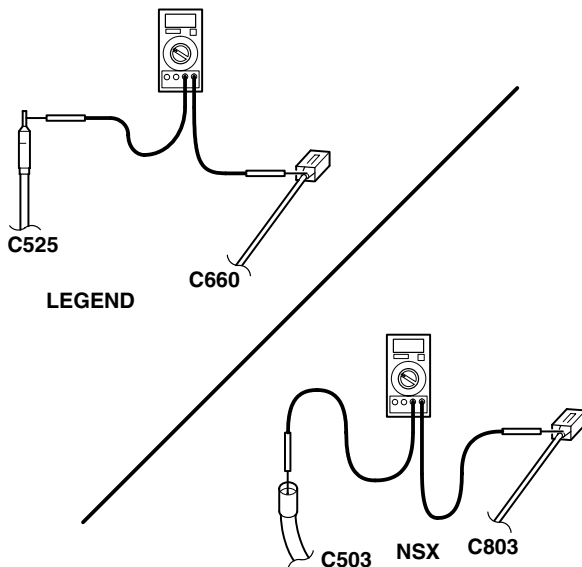

- If the resistance is less than 10 ohms, go to Window Antenna Coaxial Cable Ground Test.
- If the resistance is more than 10 ohms, continue with step 4.

- Remove the following items to access the coaxial cable connector. SRS components are located in this area. Review the SRS component locations, precautions, and procedures in the SRS section of the appropriate service manual before continuing.

- LEGEND** – Remove the lower dash panel; then locate the window antenna coaxial cable on the left side of the steering column.

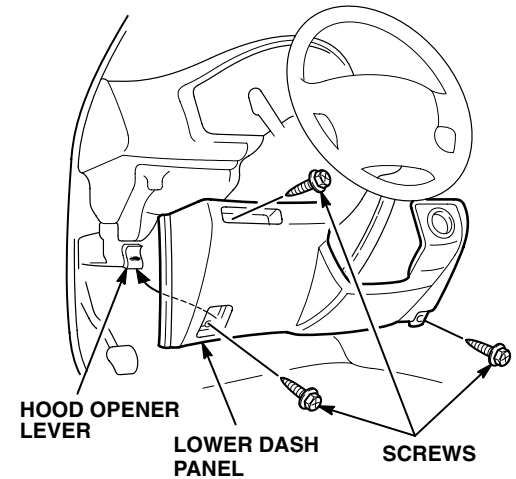

- NSX** – Move the passenger's seat forward, and remove the rear upper trim panel; then remove the right rear trim panel. Locate the window antenna coaxial cable.

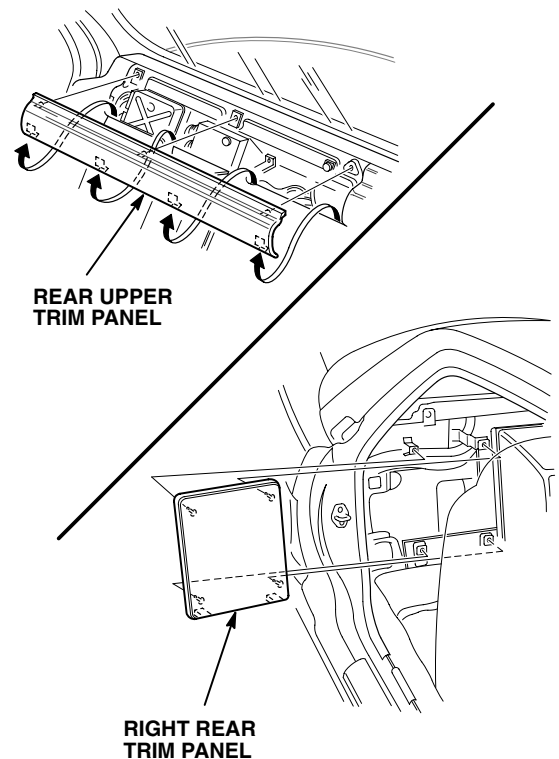

5. Disconnect the window antenna coaxial cable connector.

• **LEGEND – Connector C509**

**WINDOW ANTENNA
FRONT COAXIAL CABLE
FEMALE JACK**

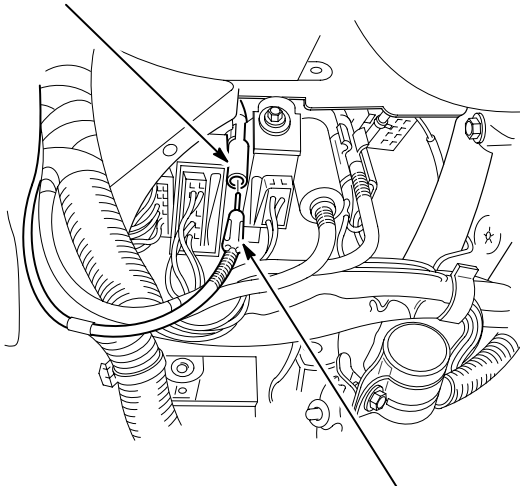

**WINDOW ANTENNA
REAR COAXIAL
CABLE MALE PLUG**

• **NSX – Connector C504**

**WINDOW ANTENNA
FRONT COAXIAL
CABLE MALE PLUG**

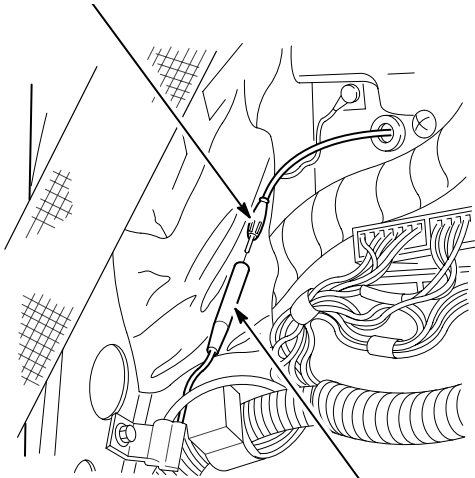

**WINDOW ANTENNA
REAR COAXIAL
CABLE FEMALE JACK**

6. Measure the resistance between the center of the window antenna front coaxial cable plug/jack, at the back of the radio, and the center of the window antenna front coaxial cable plug/jack at the connector (*Legend: C509 to C525, NSX: C504 to C503*).

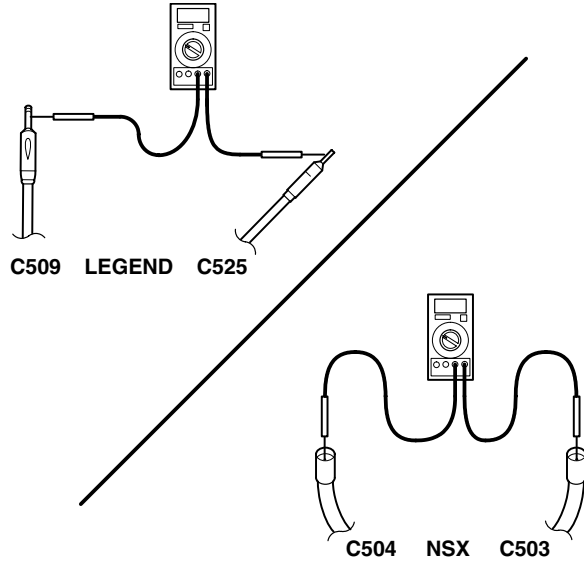

- If the resistance is more than 10 ohms, replace the window antenna front coaxial cable. Refer to PARTS INFORMATION.
- If the resistance is less than 10 ohms, replace the window antenna rear coaxial cable. Refer to PARTS INFORMATION.

Window Antenna Coaxial Cable Ground Test

1. Measure the resistance between the outer contact of the window antenna front coaxial cable plug/jack at the radio (*Legend: C525, NSX: C503*) and body ground.

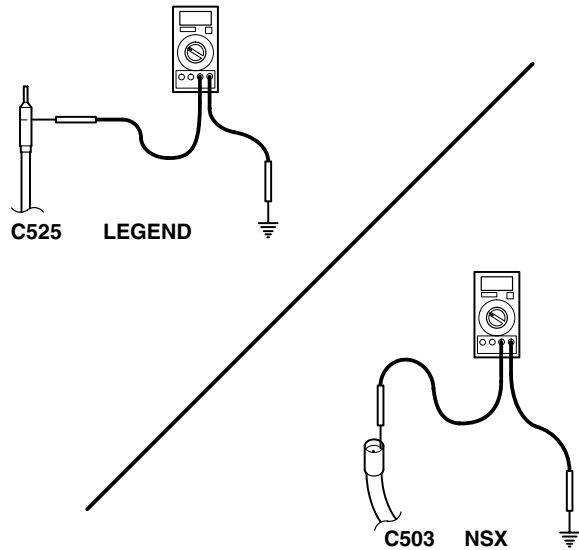

- If the resistance is more than 1 ohm, go to step 2.
- If the resistance is less than 1 ohm, continue to troubleshoot the audio system.

2. Remove the following items to access the window antenna ground bolt.

- **LEGEND** – Carefully pull down on the right rear door trim; then release the clips for the right “C” pillar trim panel. Roll the “C” pillar trim panel forward, but do not remove the attaching screw. Remove the right rear grab handle and the headliner mounting screws in the right rear corner. Carefully pull down on the headliner to release the trim clips.

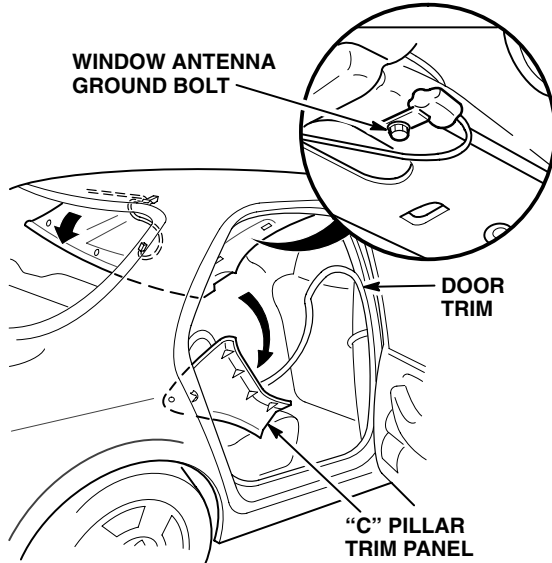

- **NSX** – Remove the right side sill pad; then pull the door trim away from the door opening. Remove the rear upper trim panel, the right rear trim panel, and the right rear side trim panel.

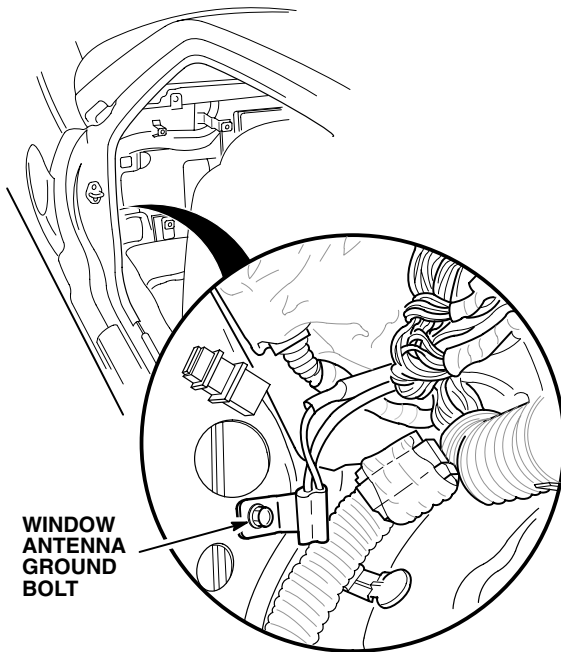

3. Check for poor ground at the ground bolt. Clean the paint from around the mounting area; then reinstall the ground bolt.
4. After cleaning the window antenna ground bolt, recheck the resistance between the outer contact of the window antenna front coaxial cable plug/jack at the radio (*Legend: C525, NSX: C503*) and body ground.

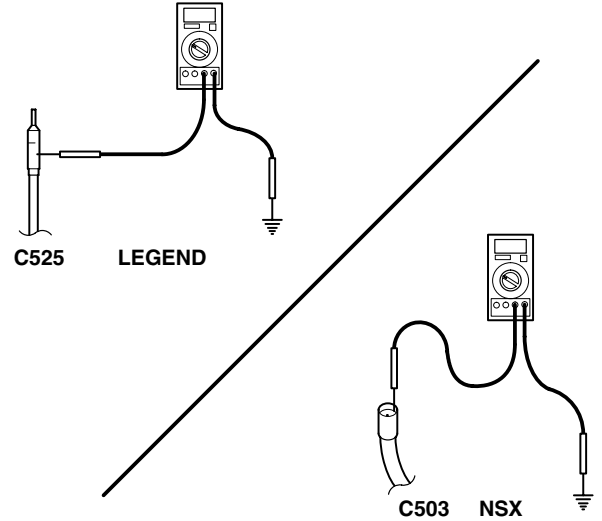

- If the resistance is more than 10 ohms, go to step 5.
 - If the resistance is less than 10 ohms, continue to troubleshoot the audio system.
5. Remove the following items to access the coaxial cable connectors. SRS components are located in this area. Review the SRS component locations, precautions, and procedures in the SRS section of the appropriate service manual before continuing.
 - **LEGEND** – Remove the lower dash panel; then locate the window antenna coaxial cable on the left side of the steering column.

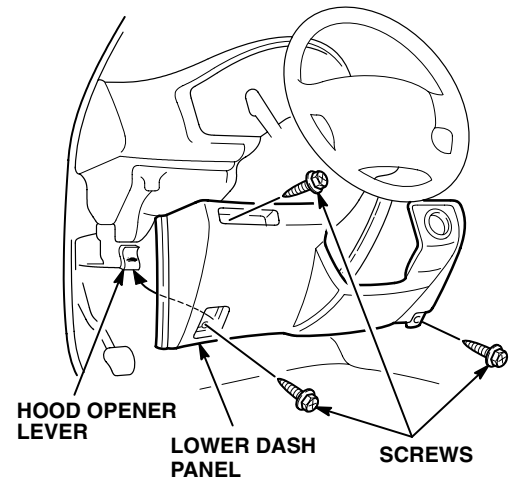

- NSX – Move the passenger’s seat forward, and remove the rear upper trim panel; then remove the right rear trim panel. Locate the window antenna coaxial cable.

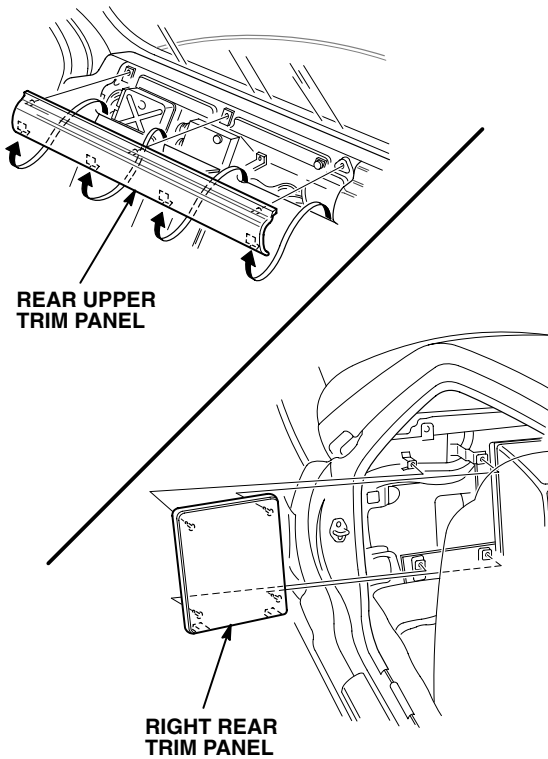

6. Disconnect the window antenna coaxial cable connector.

- LEGEND – Connector C509

WINDOW ANTENNA FRONT COAXIAL CABLE FEMALE JACK

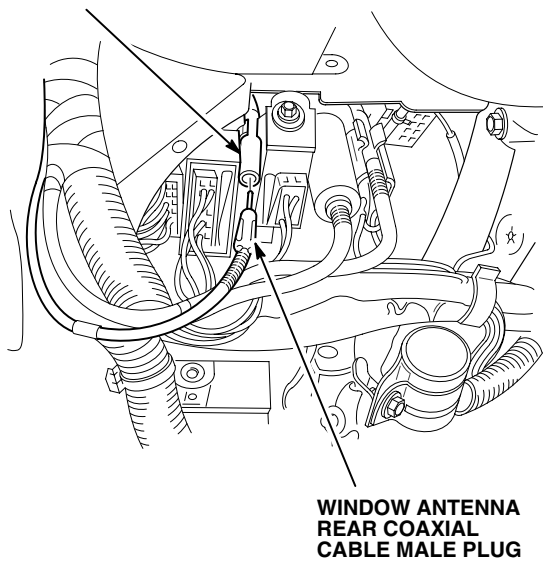

- NSX – Connector C504

WINDOW ANTENNA FRONT COAXIAL CABLE MALE PLUG

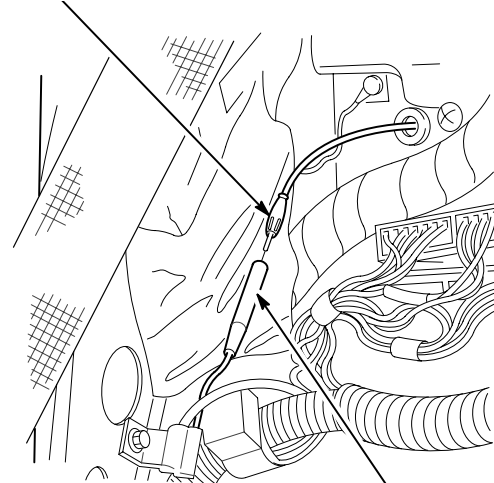

7. Measure the resistance between the outer contact of the jack/plug at the connector and body ground.

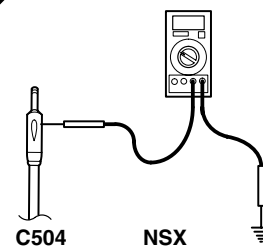
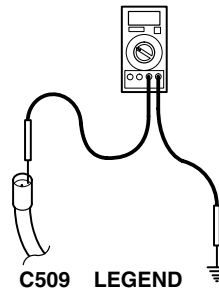

- If the resistance is more than 10 ohms, replace the window antenna rear coaxial cable. Refer to PARTS INFORMATION.
- If the resistance is less than 10 ohms, replace the window antenna front coaxial cable. Refer to PARTS INFORMATION.

CORRECTIVE ACTION

Replace the parts, listed under PARTS INFORMATION, as directed by the results of the diagnostic procedure.

Antenna Mast Replacement

1. Remove the antenna nut with the special tool.

ANTENNA NUT WRENCH
T/N 07JAA-001000C

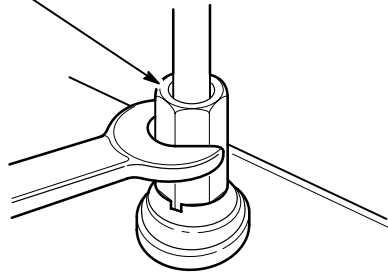

2. *NSX only*: Inspect the outer diameter of the antenna nut.

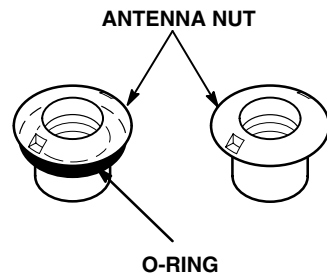

- If the antenna nut does not have an O-ring around the outer diameter, go to Antenna Mast Kit Replacement (*NSX Only*).
 - If the nut has an O-ring around the outer diameter, continue with step 3.
3. Turn the ignition switch ON; then turn the radio on to extend the antenna mast.
 4. Pull the antenna mast out of the antenna tube.

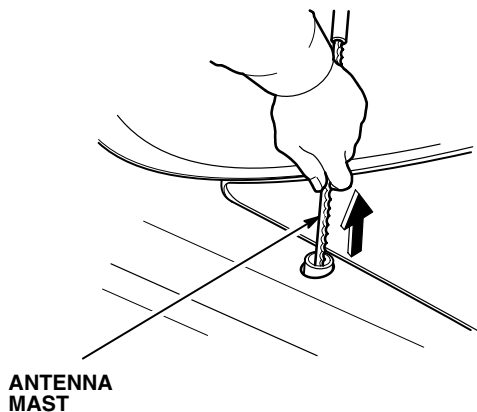

5. *Legend only* – Inspect the antenna mast to identify which mast to use for the repair. The 1991-92 Legend antenna mast is different from the 1993-94 mast. Some 1991-92 Legends have had the 1993-94 antenna assemblies installed. Make sure that you correctly identify the antenna mast that was removed so you can install the correct mast for the repair.

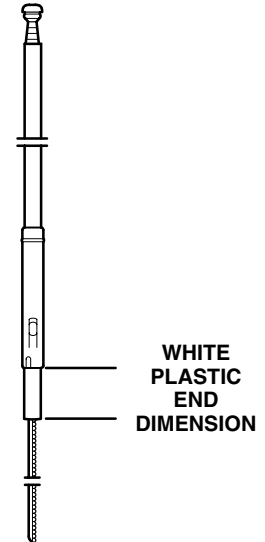

- If the mast has four sections, and the white plastic end of the antenna mast is 16 mm long, use the antenna mast assembly for the 1991-92 Legend. Refer to PARTS INFORMATION.
 - If the mast has five sections, and the white plastic end of the antenna mast is 63 mm long, use the antenna mast assembly for the 1991-92 Legend. Refer to PARTS INFORMATION.
 - If the white plastic end of the antenna mast is 29 mm long, use the antenna mast assembly for the 1993-94 Legend. Refer to PARTS INFORMATION.
6. Insert the new antenna mast assembly into the antenna tube; then turn the radio off to retract the antenna mast.

- Loosen the mounting hardware for the antenna motor assembly.

- LEGEND – Two mounting nuts

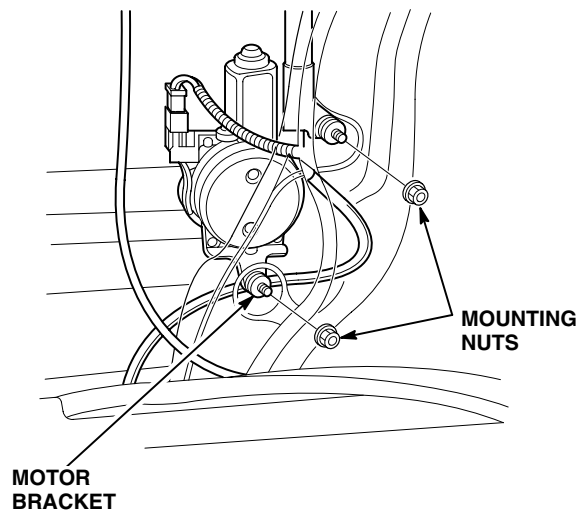

- NSX – Three mounting bolts

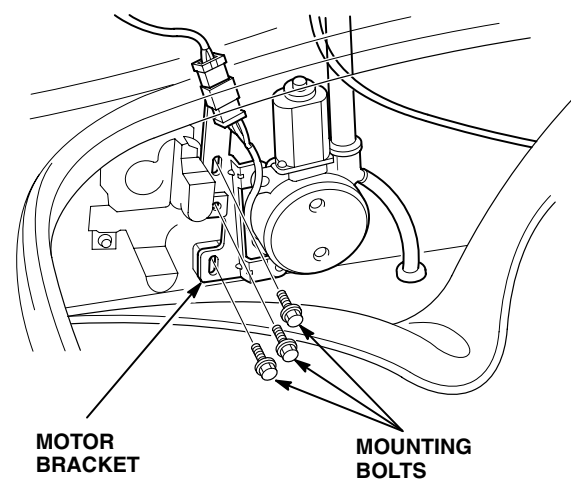

- Reinstall the antenna nut; then tighten it to 2.3 N·m (0.23 kg·m, 20 lb-in) using the special tool and a torque wrench.

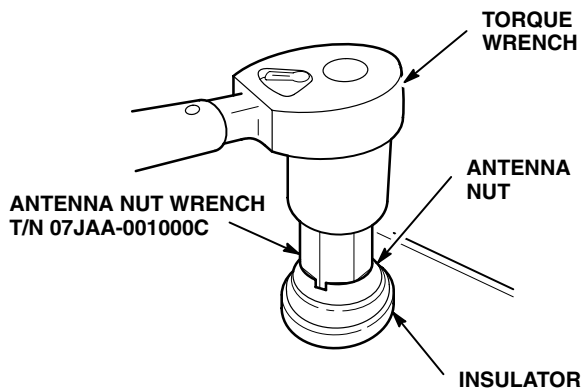

- Tighten all the antenna motor assembly mounting hardware.

Antenna Mast Kit Replacement (NSX Only)

The Antenna Mast Kit includes the mast, an improved antenna nut (O-ring type), and an insulator that provides a seat for the O-ring.

- Turn the ignition switch ON; then turn the radio on to extend the antenna mast.
- Pull the antenna mast out of the antenna tube; then discard the antenna mast.
- Remove the antenna seal, and discard it.

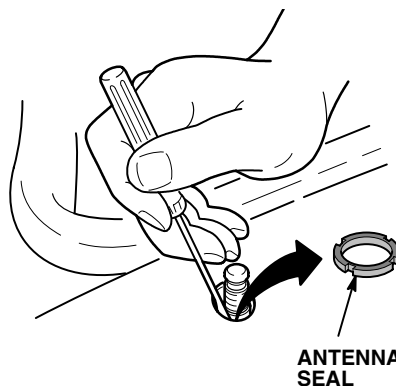

- Insert the new antenna mast into the antenna tube; then turn the radio off to retract the antenna mast.
- Loosen the three mounting bolts for the antenna motor assembly.

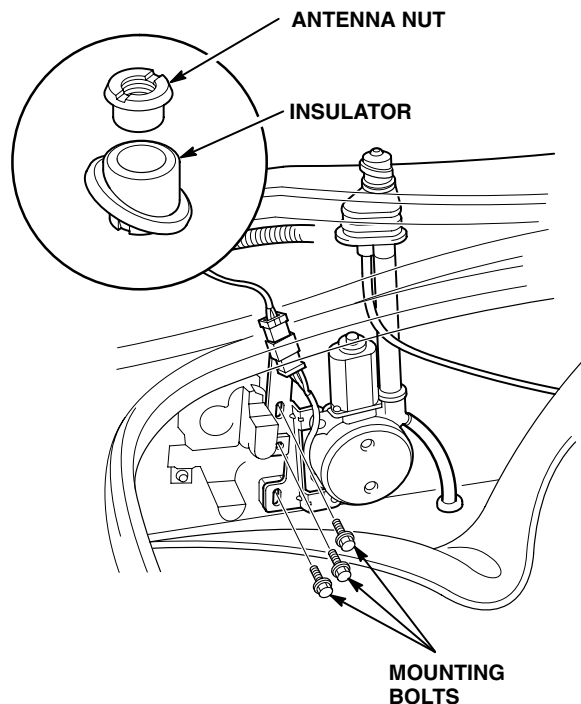

- Install the new insulator and antenna nut provided with the kit. Tighten the antenna nut to 2.3 N·m (0.23 kg·m, 20 lb-in) using the special tool and a torque wrench.
- Tighten the three mounting bolts.

Antenna Tube Replacement (Disassembly)

1. Remove the antenna nut with the special tool.

ANTENNA NUT WRENCH
T/N 07JAA-001000C

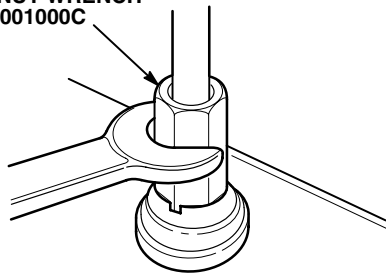

2. Inspect the antenna nut.

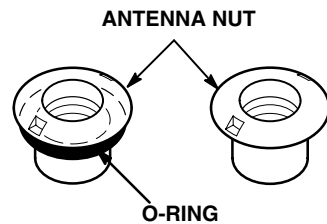

- If the antenna nut has an O-ring, do not install an antenna seal in the replacement collar.
 - If the antenna nut does not have an O-ring, you must install an antenna seal in the replacement collar.
3. Turn the ignition switch ON; then turn the radio on to extend the antenna mast.
 4. Remove the antenna mast from the antenna tube. Retain the mast.
 5. Disconnect the coaxial cable and the power connector from the antenna assembly. Loosen the lower mounting hardware; then remove the antenna assembly from the car.

• LEGEND

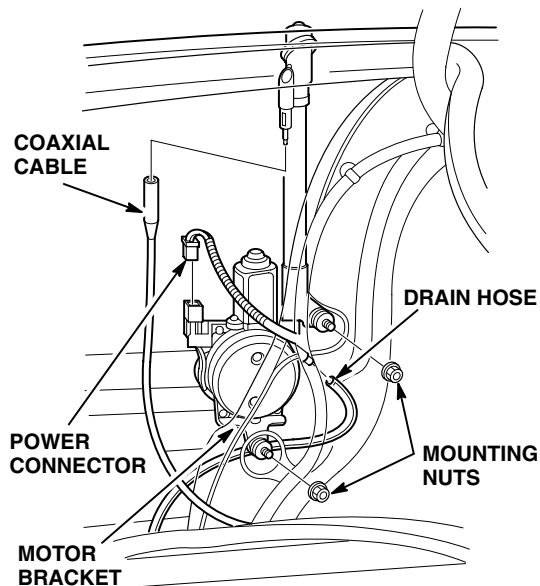

• NSX

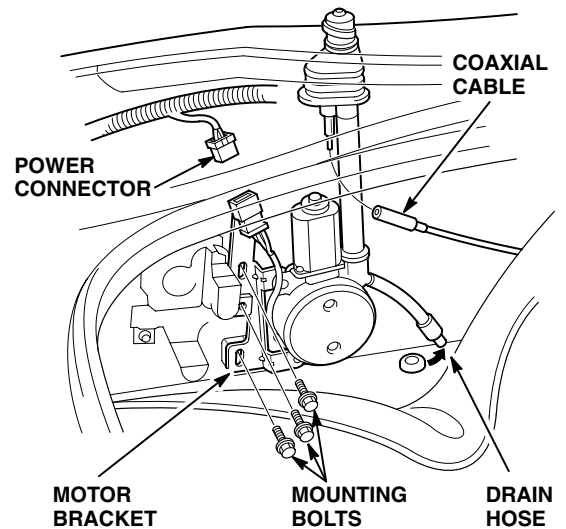

6. Remove the upper mounting bracket from the antenna tube (*Legend only*); then remove and retain the clamping screw that holds the antenna tube to the antenna assembly. Pull the antenna tube out of the antenna assembly.

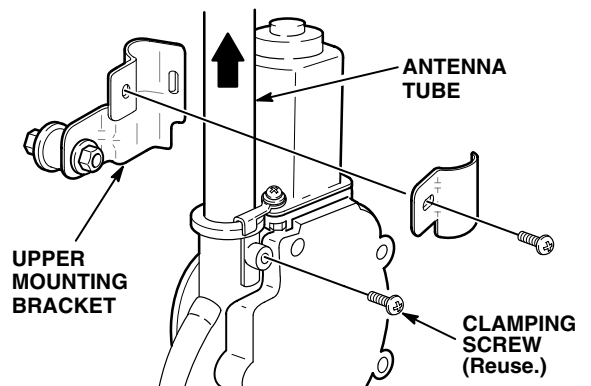

7. Remove the guide and the insulator tube from the old antenna tube. Thoroughly clean the guide and the insulator tube with contact cleaner to remove any dirt and grease.

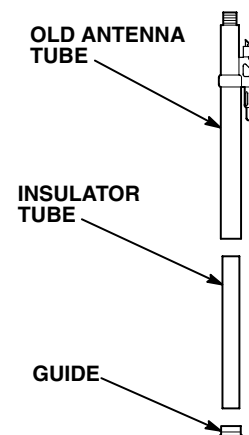

- Clean the antenna assembly drain tube with compressed air. Make sure that the tube is clear of dirt and grease.

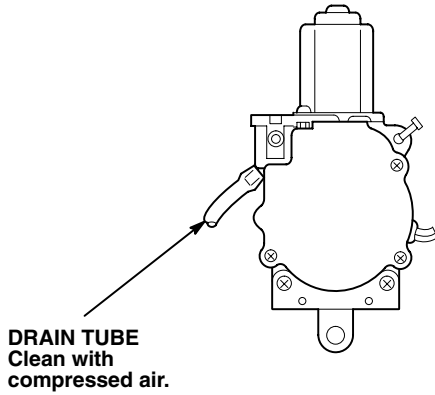

- Remove the screw and nut holding the grounding strap to the antenna motor assembly; then discard the grounding strap. Clean the area on the motor housing where the grounding strap contacts the motor, with a small wire brush.

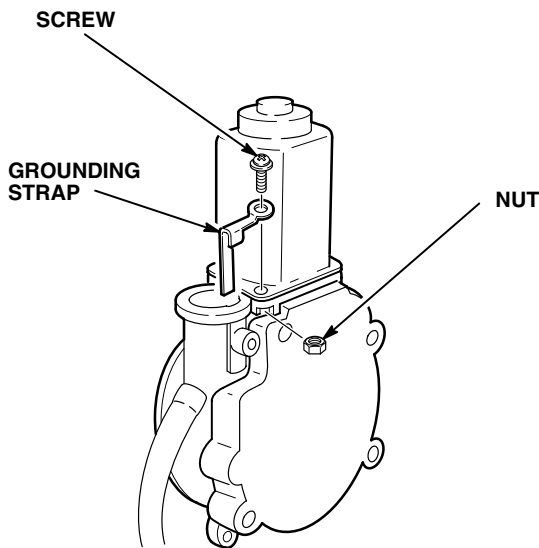

- Install the new grounding strap provided with the replacement tube, and secure it to the antenna motor assembly with the screw and nut removed in step 9.
- Install the cleaned insulator tube and guide into the replacement antenna tube.

Antenna Tube Replacement (Installation)

NOTE: Proper alignment of the antenna tube is important so that the antenna collar fits the contour of the car body. If the antenna tube is not properly aligned, the antenna collar may cause the body to deform when the antenna nut is tightened.

- Inspect the replacement antenna tube.

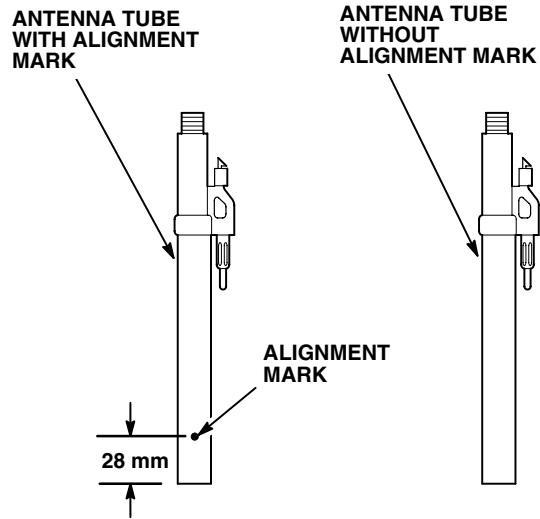

- If the replacement antenna tube has an alignment mark, go to step 18.
 - If the replacement antenna tube does not have an alignment mark, continue with step 13.
- Insert the new antenna tube without an alignment mark into the antenna assembly. Install the clamping screw removed in step 6 into the antenna assembly, but do not tighten the clamping screw at this time.

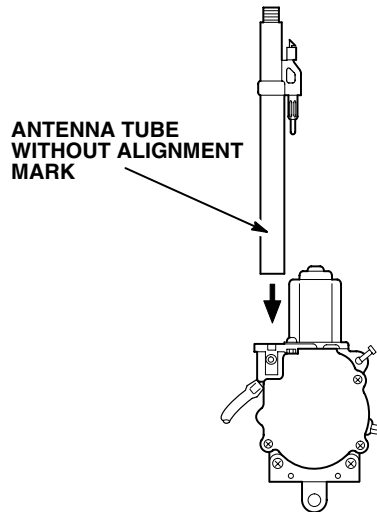

14. Temporarily install the antenna assembly in the car. Adjust the antenna tube so that the collar fits the contour of the body.

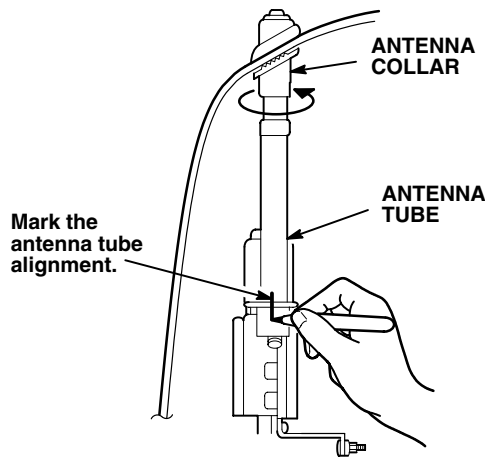

15. With the antenna tube properly adjusted, mark the tube and the antenna assembly with a felt-tip marker to note the alignment.
16. Remove the antenna assembly from the car.
17. Check the alignment of the antenna tube to the antenna assembly; then tighten the clamping screw. Once you have clamped the tube in place, go to step 19.
18. Insert the antenna tube with an alignment mark into the antenna assembly. Align the mark on the antenna tube with the clamping screw hole on the antenna assembly; then secure the tube with the clamping screw removed in step 6.

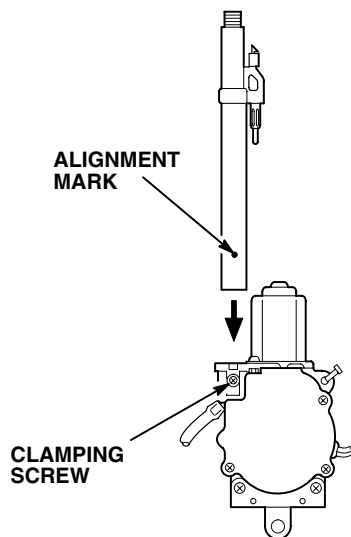

19. *Legend only* – Install the mounting bracket onto the antenna tube.
20. If the antenna nut did not have an O-ring on it, install a new collar seal into the antenna collar.

21. Install the antenna assembly into the car, but do not tighten the mounting hardware at this time.

• LEGEND

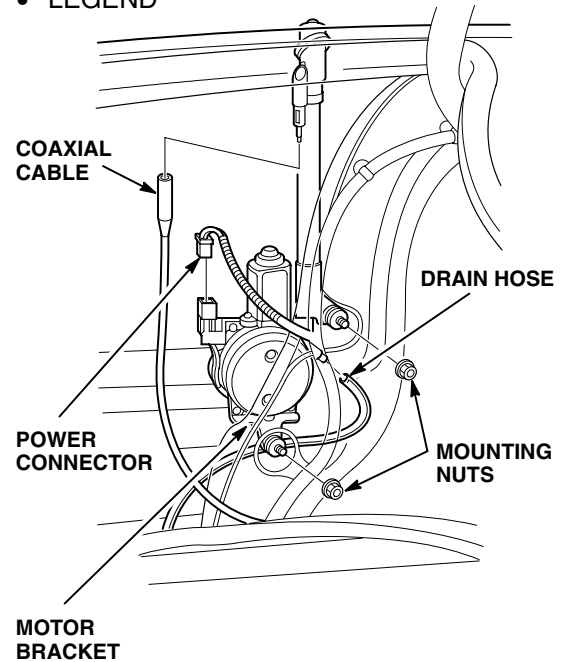

• NSX

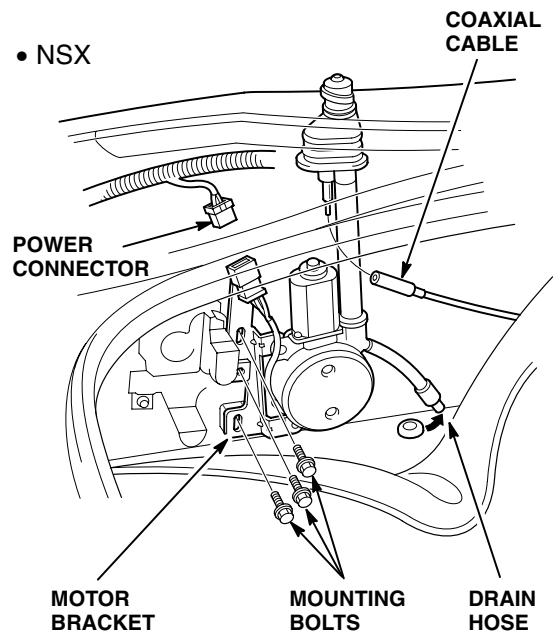

22. Connect the power connector and the coaxial cable to the antenna assembly.
23. Insert the antenna mast into the antenna tube; then turn the radio off to retract the antenna mast.

24. Install the insulator and the antenna nut. Tighten the antenna nut to 2.3 N·m (0.23 kg·m, 20 lb-in) using the special tool and a torque wrench.

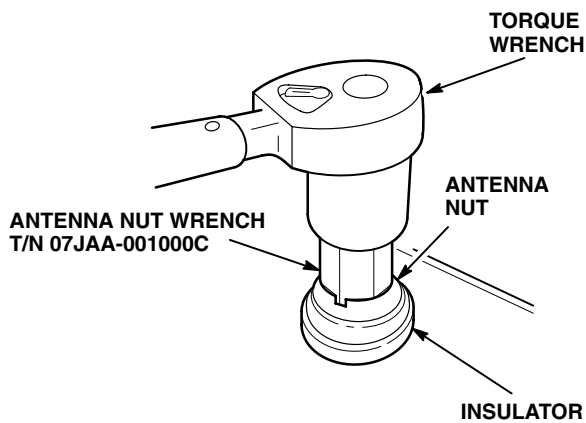

25. Tighten the antenna motor assembly mounting hardware.

Antenna Collar Replacement

1. Remove the antenna nut with the special tool.

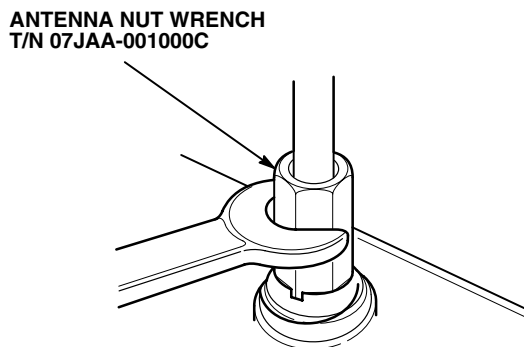

2. Inspect the antenna nut.

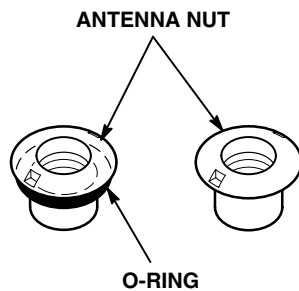

- If the antenna nut has an O-ring, do not install an antenna seal in the replacement collar.
- If the antenna nut does not have an O-ring, you must install an antenna seal in the replacement collar.

3. Disconnect the coaxial connector and the power connector from the antenna assembly. Loosen the mounting hardware; then remove the antenna assembly from the car.

• LEGEND

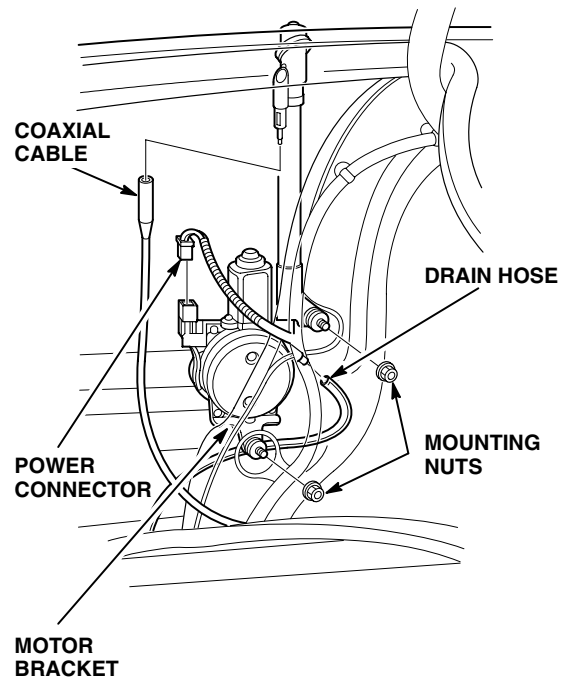

• NSX

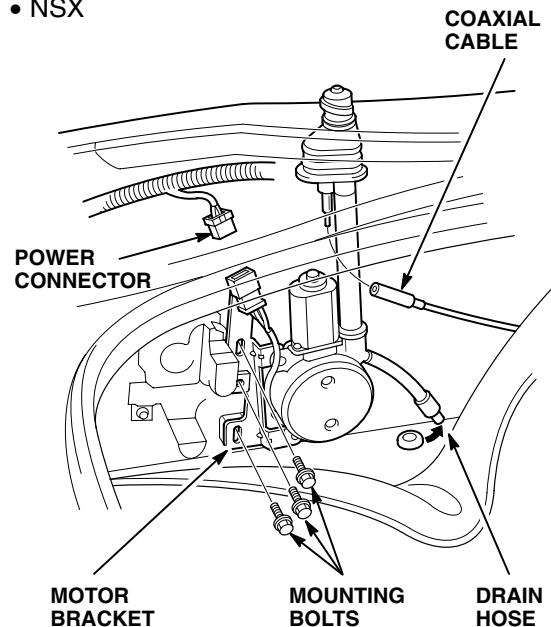

- Remove and discard the antenna collar.

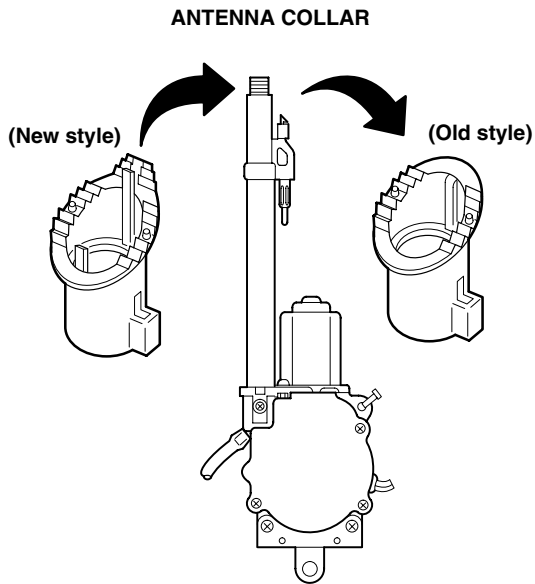

- Install the new antenna collar onto the antenna tube.
- If the antenna nut did not have an O-ring on it, install a new collar seal into the antenna collar.
- Install the antenna assembly into the car, but do not tighten the mounting hardware at this time.
- Connect the power connector and the coaxial connector to the antenna assembly.
- Install the insulator and the antenna nut. Tighten the antenna nut to 2.3 N·m (0.23 kg·m, 20 lb-in) using the special tool and a torque wrench.

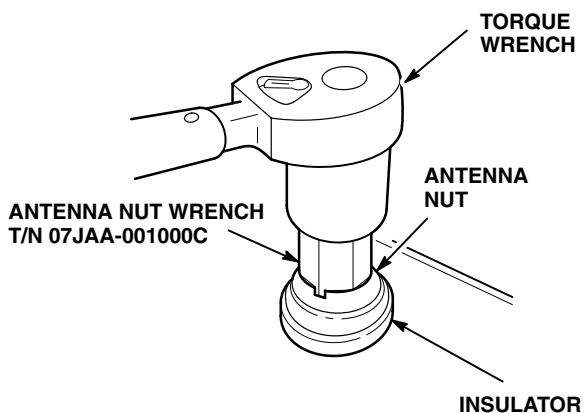

- Tighten the antenna motor assembly mounting hardware.

Window Antenna Repair

NOTE: To allow for an effective repair, the broken section must be no longer than one inch.

- Lightly rub the area around the the broken grid line with fine steel wool; then clean it with isopropyl alcohol.
- Carefully mask above and below the broken grid line of the window antenna with cellophane tape.

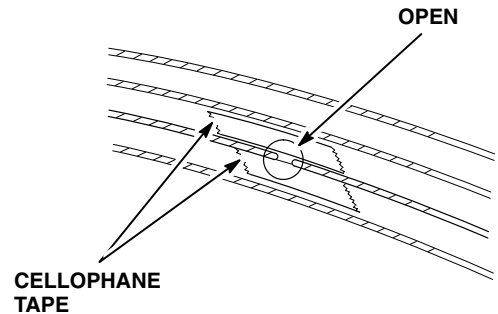

- Use a commercially available rear window defogger repair kit (Loctite # 15067 or equivalent) to repair the broken section of the grid line. Apply the conductive resin paint following the manufacturer's instructions.

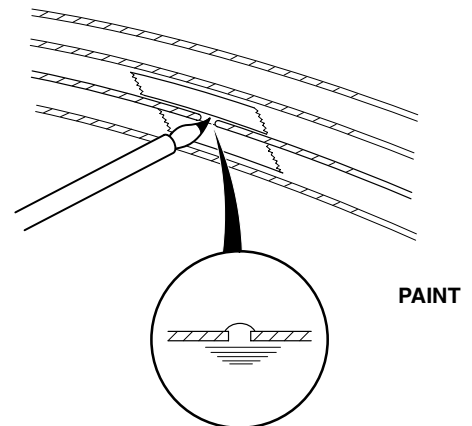

- When the conductive resin paint is dry, recheck for continuity in the repaired section of the window antenna grid line.
 - If there is continuity, remove the cellophane tape from the repaired section.
 - If there is no continuity, recheck the grid line for other breaks, and repair the window antenna as needed.

PARTS INFORMATION

Legend Coupe

Antenna Mast Assembly (1991-92):
P/N 39152-SP0-305

Antenna Mast Assembly (1993-94):
P/N 39152-SP0-A04

Antenna Tube:
P/N 39179-SP1-G02

Antenna Collar:
P/N 39168-SP1-A01

Power Antenna Coaxial, Front:
P/N 39157-SP0-A01

Power Antenna Coaxial, Rear:
P/N 39159-SP0-A01

Window Antenna Coaxial, Front:
P/N 39158-SP0-A01

Window Antenna Coaxial, Rear
P/N 39160-SP1-A00

Legend Sedan

Antenna Mast Assembly (1991-92):
P/N 39152-SP0-305

Antenna Mast Assembly (1993-94):
P/N 39152-SP0-A04

Antenna Tube:
P/N 39179-SP0-013

Antenna Collar:
P/N 39168-SP0-A01

Power Antenna Coaxial Cable, Front:
P/N 39157-SP0-A01

Power Antenna Coaxial Cable, Rear:
P/N 39159-SP0-A01

Window Antenna Coaxial Cable, Front:
P/N 39158-SP0-A01

Window Antenna Coaxial Cable, Rear:
P/N 39160-SP0-A02

NSX

Antenna Mast Kit:
P/N 39177-SL0-305

Antenna Mast Assembly:
P/N 39152-SL0-A01

Antenna Nut (O-Ring Type):
P/N 39154-SR4-013

Antenna Insulator (O-Ring Type):
P/N 39156-SL0-013

Antenna Seal:
P/N 39169-SL0-003

Antenna Tube:
P/N 39179-SL0-G02

Antenna Collar:
P/N 39168-SL0-A01

Power Antenna Coaxial Cable, Front:
P/N 39159-SL0-A01

Power Antenna Coaxial Cable, Rear (1991-92):
P/N 39172-SL0-A01

Power Antenna Coaxial Cable, Rear (1993-94):
P/N 39172-SL0-A02

Window Antenna Coaxial Cable, Front
(1991 to VIN 000319):
P/N 39166-SL0-A01

Window Antenna Coaxial Cable, Front
(1991, from VIN 000320, thru 1994):
P/N 39166-SL0-A02

Window Antenna Coaxial Cable, Rear
(1991 to VIN 000318):
P/N 39160-SL0-A01

Window Antenna Coaxial Cable, Rear
(1991, from VIN 000319, thru 1994):
P/N 39160-SL0-A02

WARRANTY CLAIM INFORMATION

In warranty: The normal warranty applies.

Out of warranty: Any repair performed after warranty expiration may be eligible for goodwill consideration by the District Technical Manager or your Zone Office. You must request consideration, and get a decision, before starting work.

OPERATION NUMBER	DESCRIPTION	FLAT RATE TIME
015120	Mast Assembly Replacement (Includes diagnosis)	0.3 hour
015125	Mast Kit Replacement (Includes diagnosis)	0.3 hour
015126	Antenna Tube Replacement With Alignment Mark (Includes diagnosis)	0.3 hour
015129	Antenna Tube Replacement Without Alignment Mark (Includes diagnosis)	0.4 hour
015127	Antenna Collar Replacement (Includes diagnosis)	0.2 hour
015128	Coaxial Cable Replacement (Includes road test and diagnosis)	0.7 hour

Failed P/N: Use the part number of the part that failed.

Contention code: F99

Defect code: Select the appropriate defect code:
018 – Broken or chipped, in two or more pieces
030 – Binding or sticking
068 – Open or burned-out circuit